

panel sheet 0,5 - 4,0

standard finishing: hardened and tempered + anticorrosive oil

MODIFICATION	DATE	DESCRIPTION	SIGN
		PART NAME	
		<b>Multi thread u-type nut - metric screw 4 MA</b>	
		PART NUMBER	
		DRAW ID	
		WEIGHT	
		TOLERANCE	
		RAW MATERIAL	
		HEAT TREATMENT	
		HARDNESS	
		DESIGNED: S.V.	DATE: 26/11/2014
		APPROVED: L.P.	DATE: 26/11/2014
		REPLACES:	
		REPLACED BY:	

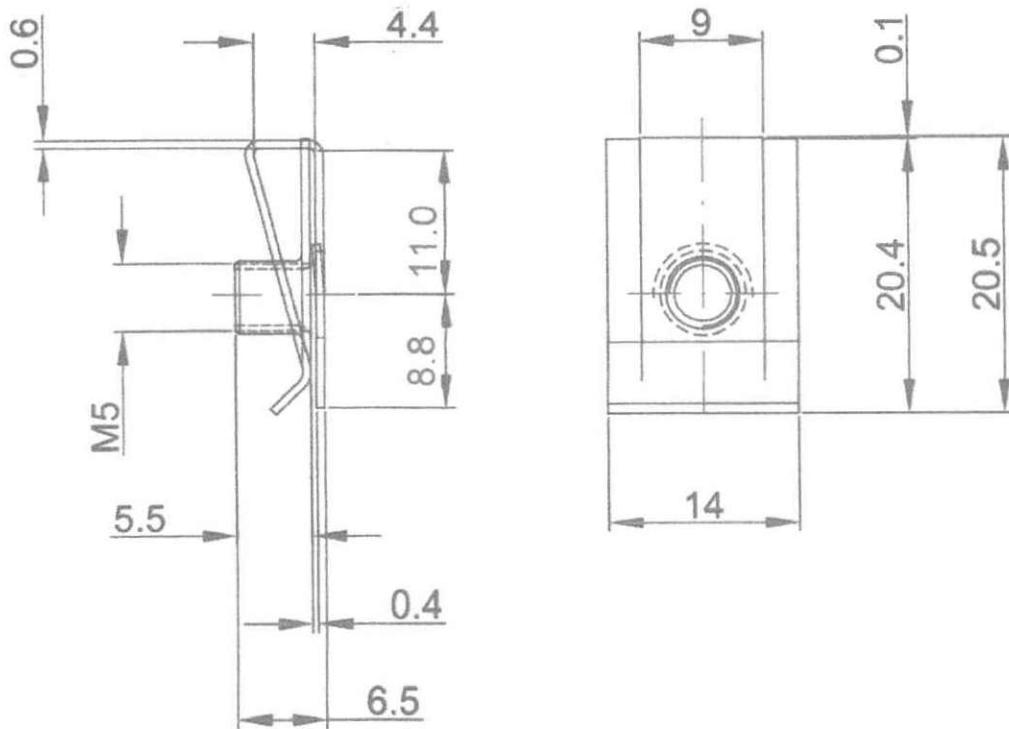

panel sheet 0.5 - 4.0

standard finishing: hardened and tempered + anticorrosive oil

MODIFICATION	DATE	DESCRIPTION	SIGN
		PART NAME	
		<b>Multi thread u-type nut - metric screw 5 MA</b>	
		DRAW ID	PART NUMBER
		SCALE	TOLERANCE
		<b>2/1</b>	<b>± 0.2</b>
		RAW MATERIAL	TREATMENT
		EN 1.1209/C50E (EN 10132-3)	<b>Hardened + tempered</b>
		DESIGNED: SL..	DATE: 11/04/13
		APPROVED: L.P.	DATE: 11/04/13
		REPLACES:	
		REPLACED BY:	
		HARDNESS	
		HRc: 38+42	
		HR15N: 79.5+81.5	

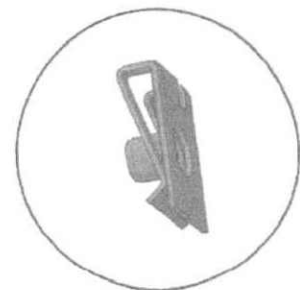
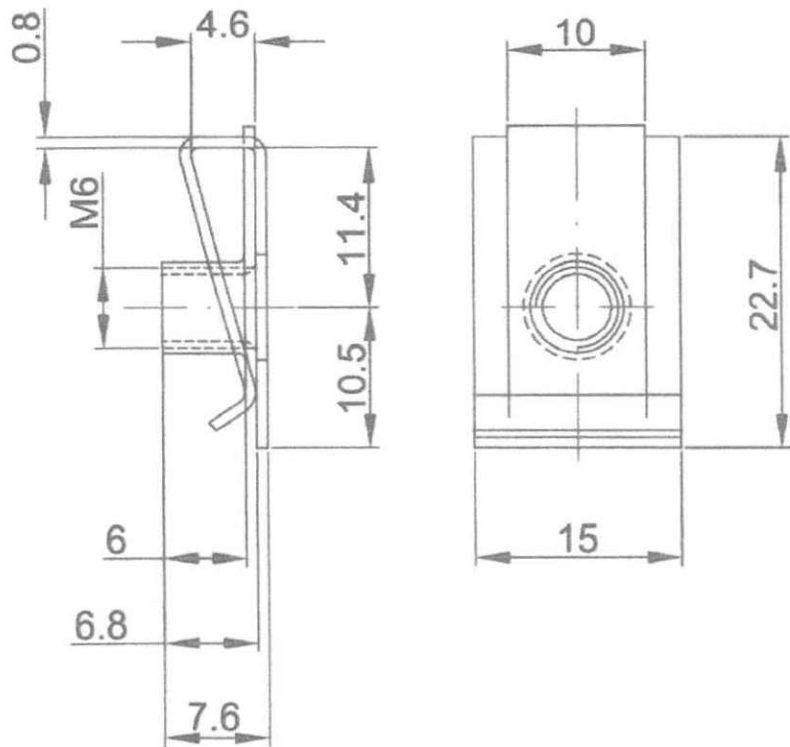

standard finishing: hardened and tempered + anticorrosive oil

MODIFICATION	DATE	DESCRIPTION	SIGN
		PART NAME	
		Multi thread U-type nut - metric screw 6 MA	
DRAW ID	PART NUMBER	SCALE	TOLERANCE
		2/1	± 0.2
RAW MATERIAL	TREATMENT	HARDNESS	
EN 1.1191/C45E	Hardened + tempered	HRC: 39+43 HR15N: 80.5+81.5	
DESIGNED: S.V.	DATE: 18/07/08	REPLACES: .	
APPROVED: L.P.	DATE: 18/07/08	REPLACED BY: .	